

# Indoor Air Quality Application Note



## Overview

Indoor air quality is a large market that is currently experiencing rapid growth due to the combined pressures of urbanisation, industrialisation and an increasing awareness of the importance of clean air for improved health and to prevent the transmission of respiratory diseases like COVID-19.

## Improving the accuracy of air quality sensors

Air quality sensors that measure VOCs and particulates (PM1 and PM2.5) can be very sensitive to even small changes in the sample flow rate.

Adding flow measurement using the FLS110 allows the response of these sensors to be compensated for small changes in flow rate. This improves their accuracy and also allows the sensors to be used when the sampling flow rate is variable.

## Eliminate sampling fans

With traditional air quality monitoring a sampling pump or fan is used to draw a known flow rate of air through the sensors. This flow rate must remain constant or the sensor readings will drift.

With the FLS110 the flow through the sensors can be measured and the sensor readings compensated for the flow rate which greatly improves their accuracy.

This allows the sampling fan to be eliminated and the sensors can operate with a small bypass flow from the main fan.

It also simplifies the design and manufacturing; reduces cost; and removes a moving part which can be a point of failure and source of noise.

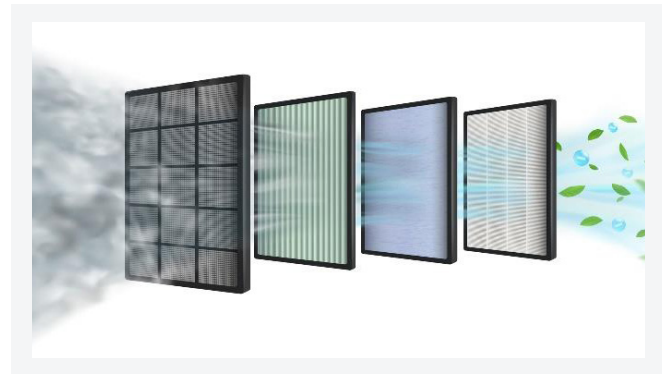

Changing filters at the right time is key to reducing waste, energy use and maintaining product performance.

## Filter life monitoring

Consumers can quickly become frustrated if they are asked to change a filter that doesn't need to be replaced or if the product stops working without warning due to a clogged filter.

Many consumers simply reset the filter change timer within a product if they think the filter doesn't need changing. This results in poor product performance as the filter is then overloaded before the user is asked to change the filter again.

The FLS110 provides accurate system flow measurement allowing filters to be continuously monitored to predict the remaining useful life. This eliminates customer frustration due to inaccurate filter change warnings and ensures the product is always performing at its best.

The FLS110 eliminates the sampling fan, provides accurate flow measurement of system flow rate, and improves the accuracy of air quality sensors.

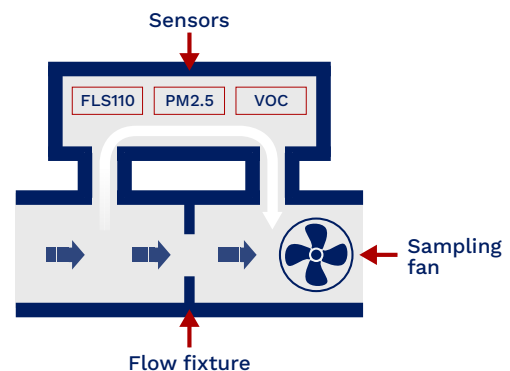
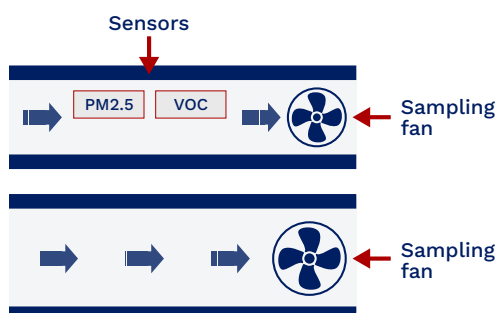

# Indoor Air Quality Application Note



## Reduce power consumption and noise

The FLS110 directly measures mass flow rate accurately across changes in atmospheric pressure and temperature.

This makes it ideal for monitoring the clean air delivery rate (CADR) of an air purifier. This allows the fan speed of the product to be adjusted to maintain a target CADR whilst minimising noise and power consumption.

The target CADR can be controlled based on the size of the room and its occupancy to maintain excellent indoor air quality.

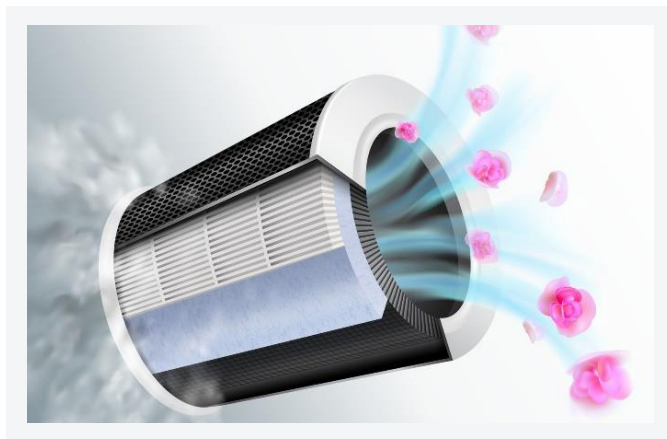

Monitoring clean air delivery rate is key to maintaining air quality while minimising noise and power consumption.

## FLS110 evaluation kit

This kit contains everything you'll need. It's supplied with a fluidic fixture (to fit your flow range), push-fit connectors and a USB adapter to connect the FLS110 PCB directly to your PC.

And once you have everything connected together, you can easily recalibrate the sensor to take account of your complete system.



Using our FLS110 evaluation kit you can be measuring flow within minutes.



Scan QR Code for more information or to order a flow sensor evaluation kit



### Flusso Ltd

Deanland House  
160 Cowley Rd  
Cambridge, CB4 0DL, UK  
Email: [sales@flussoltd.com](mailto:sales@flussoltd.com)  
[www.flussoltd.com](http://www.flussoltd.com)